

吸盘组件选型

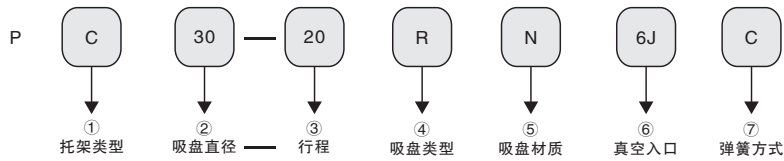

①托架类型

记号	C	D
	弹簧式 侧吸口	直接型 固定式
形状		

④吸盘类型

记号	标准型	波纹风箱型	椭圆形	防滑型
类形				
	(R)	(B)	(E)	(KNH)

②吸盘直径

单位: mm

代码	4	6	8	10	15	20	25	30	35	40	50	
直径 (mm)	标准型	φ4	φ6	φ8	φ10	φ15	φ20	φ25	φ30	-	φ40	φ50
	波纹风箱型	-	-	-	φ10	-	φ20	-	φ30	-	φ40	φ50
	防滑型	-	-	-	φ10	-	φ20	-	φ30	-	φ40	φ50
	椭圆形	-	-	-	φ10	-	φ20	-	φ30	-	-	-

A \ B	10mm	20mm	30mm
4mm	4 × 10	4 × 20	4 × 30
5mm	5 × 10	5 × 20	5 × 30
6mm	6 × 10	6 × 20	6 × 30
8mm	-	8 × 20	8 × 30

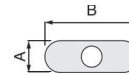

③行程

记号	10	15	20	30	40	50
行程	10mm	15mm	20mm	30mm	40mm	50mm

⑤吸盘材质

材料	丁腈橡胶	硅橡胶	防静电硅橡胶	防静电丁腈橡胶	防滑橡胶
标准型	N	S	SE	NE	-
波纹风箱型	N	S	SE	NE	-
椭圆形	N	S	SE	NE	-
防滑型	-	-	-	-	KNH

①可特殊定制材料
(F-氟橡胶、
U-聚氨酯橡胶)

注: 上述以外材质也可定制, 可与我公司协商, 详见前附04。

⑥真空入口

接口方式	代码	适用规格	吸盘直径(mm)	
			φ4-φ8	φ10-φ50
快插接头	4J	φ4 × 2.5 软管	●	-
	6J	φ6 × 4 软管	-	●
笋型接头	4B	φ4 × 2.5 软管	●	-
	6B	φ6 × 4 软管	-	●

⑦弹簧方式

记号	无代码	C
方式	内置弹簧	外置弹簧
行程	10mm-20mm	20mm-50mm

特性:

这种真空吸盘即使吸盘到零件的距离变动时, 也能固定住零件或材料。
 标准型: 适合厚的扁平制品的常规型真空和适合球形果子或球的深凹型。
 波纹风箱型: 最适合反驳包装, 食品包装袋。
 椭圆形: 最适合于长的制品如衬底或半导体。
 防滑型: 最适合于输送涂膜件, 如冲压件。
 使用便携的结构设计, 更换吸盘时不必再将吸盘托架从设备上取下。

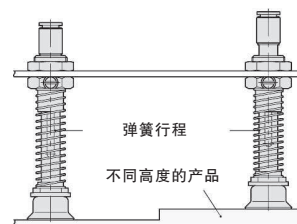

PC 长行程顶部真空端口
常规型—内置弹簧

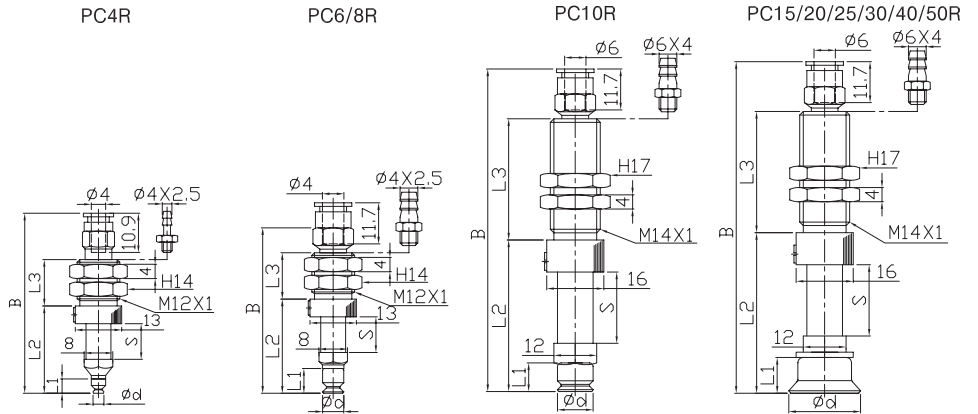

单位: mm



型号	吸盘 外径(ød)	B	L1	L2	L3	S 行程	质量 (g)
PC4-10R□4J/4B	4	57	4	27	17.5	10	21
PC4-15R□4J/4B		68		32	23.5	15	24
PC4-20R□4J/4B		78		37	28.5	20	27
PC6-10R□4J/4B	6	56.5	7	26.5	17.5	10	20
PC6-15R□4J/4B		67.5		31.5	23.5	15	24
PC6-20R□4J/4B		77.5		36.5	28.5	20	26
PC8-10R□4J/4B	8	55	5.5	25	17.5	10	20
PC8-15R□4J/4B		66		30	23.5	15	24
PC8-20R□4J/4B		76		35	28.5	20	26
PC10-10R□6J/6B	10	64.5	8	30.5	20	10	37
PC10-15R□6J/6B		74.5		35.5	25	15	42
PC10-20R□6J/6B		90.5		42.5	34	20	49
PC15-10R□6J/6B	15	65.5	9	31.5	20	10	37
PC15-15R□6J/6B		75.5		36.5	25	15	42
PC15-20R□6J/6B		91.5		43.5	34	20	50
PC20-10R□6J/6B	20	68	10	34	20	10	42
PC20-15R□6J/6B		78		39	25	15	47
PC20-20R□6J/6B		94		46	34	20	54
PC25-10R□6J/6B	25	69	11	35	20	10	43
PC25-15R□6J/6B		79		40	25	15	48
PC25-20R□6J/6B		95		47	34	20	54
PC30-10R□6J/6B	30	69	11	35	20	10	45
PC30-15R□6J/6B		79		40	25	15	50
PC30-20R□6J/6B		95		47	34	20	57
PC40-10R□6J/6B	40	72	14	38	20	10	52
PC40-15R□6J/6B		82		43	25	15	57
PC40-20R□6J/6B		98		50	34	20	66
PC50-10R□6J/6B	50	73	15	39	20	10	58
PC50-15R□6J/6B		83		44	25	15	63
PC50-20R□6J/6B		99		51	34	20	69

PC 长行程顶部真空端口
常规型—外置弹簧

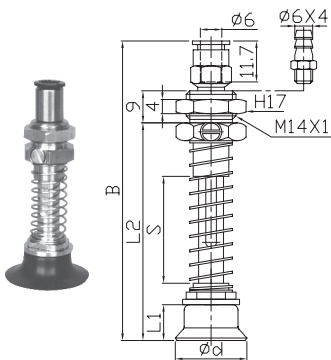

单位: mm

型号	吸盘 外径(ød)	B	L1	L2	S 行程	质量 (g)
PC20-20R□6JC/6BC	20	71	10	48	20	50
PC20-30R□6JC/6BC		84		61	30	55
PC20-40R□6JC/6BC		97		74	40	60
PC20-50R□6JC/6BC		110		87	50	65
PC25-20R□6JC/6BC	25	72	11	49	20	50
PC25-30R□6JC/6BC		85		62	30	55
PC25-40R□6JC/6BC		98		75	40	61
PC25-50R□6JC/6BC		111		88	50	66
PC30-20R□6JC/6BC	30	72	11	49	20	52
PC30-30R□6JC/6BC		85		62	30	57
PC30-40R□6JC/6BC		98		75	40	63
PC30-50R□6JC/6BC		111		88	50	68
PC40-20R□6JC/6BC	40	75	14	52	20	59
PC40-30R□6JC/6BC		88		65	30	65
PC40-40R□6JC/6BC		101		78	40	70
PC40-50R□6JC/6BC		114		91	50	75
PC50-20R□6JC/6BC	50	76	15	53	20	65
PC50-30R□6JC/6BC		89		66	30	70
PC50-40R□6JC/6BC		102		79	40	76
PC50-50R□6JC/6BC		115		92	50	81

备注: 1.表格内□填入吸盘材质, 多种材质可以选择, 不同应用选用不同材质的吸盘。
2.所有金属支架的接头4J&4B可以互换, 6J&6B可以互换, 6JC&6BC可以互换。

- 标准型
- 波纹型
- 柔软型
- 柔软波纹型
- 椭圆形
- 薄物用型
- 防滑型
- 长行程型
- M F 型
- M J 型
- M C 型
- M A 型
- G U 型
- G C 型
- G B 型
- 防掉落阀

真空吸盘组件—长行程—波纹风箱型

GINIER®
http://www.ginier.net

PC 长行程顶部真空端口
波纹风箱型—内置弹簧

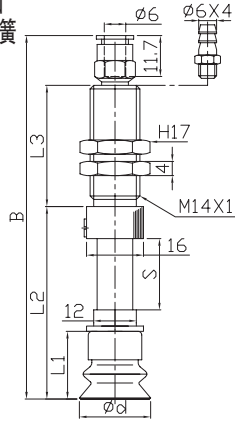

型号	吸盘 外径(φd)	B	L1	L2	L3	S 行程	质量 (g)
PC10-10B□6J/6B	10	72.5	16	38.5	20	10	37
PC10-15B□6J/6B		82.5		43.5	25	15	42
PC10-20B□6J/6B		98.5		50.5	34	20	50
PC20-10B□6J/6B	20	77	19	43	20	10	42
PC20-15B□6J/6B		87		48	25	15	47
PC20-20B□6J/6B		103		55	34	20	54
PC30-10B□6J/6B	30	81	23	47	20	10	46
PC30-15B□6J/6B		91		52	25	15	51
PC30-20B□6J/6B		107		59	34	20	58
PC40-10B□6J/6B	40	88	30	54	20	10	55
PC40-15B□6J/6B		98		59	25	15	59
PC40-20B□6J/6B		114		66	34	20	66
PC50-10B□6J/6B	50	90	32	56	20	10	60
PC50-15B□6J/6B		100		61	25	15	65
PC50-20B□6J/6B		116		68	34	20	72

PC 长行程顶部真空端口
波纹风箱型—外置弹簧

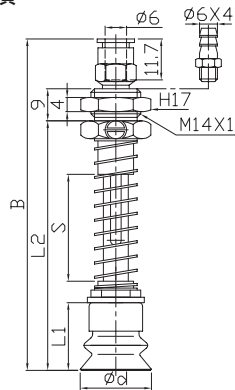

型号	吸盘 外径(φd)	B	L1	L2	S 行程	质量 (g)
PC20-20B□6JC/6BC	20	80	19	57	20	50
PC20-30B□6JC/6BC		93		70	30	55
PC20-40B□6JC/6BC		106		83	40	60
PC20-50B□6JC/6BC	30	119	23	96	50	65
PC30-20B□6JC/6BC		84		61	20	53
PC30-30B□6JC/6BC		97		74	30	58
PC30-40B□6JC/6BC	40	110	30	87	40	64
PC30-50B□6JC/6BC		123		100	50	69
PC40-20B□6JC/6BC		91		68	20	62
PC40-30B□6JC/6BC	50	104	32	81	30	67
PC40-40B□6JC/6BC		117		94	40	72
PC40-50B□6JC/6BC		130		107	50	78
PC50-20B□6JC/6BC	50	93	32	70	20	68
PC50-30B□6JC/6BC		106		83	30	73
PC50-40B□6JC/6BC		119		96	40	78
PC50-50B□6JC/6BC	132	109	50	83		

PD 长行程侧面真空端口
波纹风箱型—内置弹簧

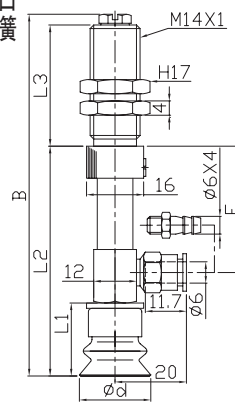

型号	吸盘 外径(φd)	B	L1	L2	L3	E	S 行程	质量 (g)
PD10-10B□6J/6B	10	71	16	48	20	25	10	51
PD10-15B□6J/6B		81		53	25	30	15	57
PD10-20B□6J/6B		97		60	34	37	20	67
PD20-10B□6J/6B	20	75	19	52	20	24.5	10	55
PD20-15B□6J/6B		85		57	25	29.5	15	62
PD20-20B□6J/6B		101		64	34	36.5	20	72
PD30-10B□6J/6B	30	79	23	56	20	24.5	10	59
PD30-15B□6J/6B		89		61	25	29.5	15	65
PD30-20B□6J/6B		105		68	34	36.5	20	75
PD40-10B□6J/6B	40	86	30	63	20	24.5	10	68
PD40-15B□6J/6B		96		68	25	29.5	15	74
PD40-20B□6J/6B		112		75	34	36.5	20	84
PD50-10B□6J/6B	50	88	32	65	20	24.5	10	73
PD50-15B□6J/6B		98		70	25	29.5	15	80
PD50-20B□6J/6B		114		77	34	36.5	20	90

PD 长行程侧面真空端口
波纹风箱型—外置弹簧

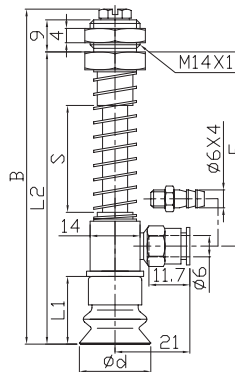

型号	吸盘 外径(φd)	B	L1	L2	E	S 行程	质量 (g)
PD20-20B□6JC/6BC	20	80.5	19	68.5	41	20	70
PD20-30B□6JC/6BC		93.5		81.5	54	30	77
PD20-40B□6JC/6BC		106.5		94.5	67	40	83
PD20-50B□6JC/6BC		119.5		107.5	80	50	90
PD30-20B□6JC/6BC	30	84.5	23	72.5	41	20	72
PD30-30B□6JC/6BC		97.5		85.5	54	30	79
PD30-40B□6JC/6BC		110.5		98.5	67	40	85
PD30-50B□6JC/6BC		123.5		111.5	80	50	92
PD40-20B□6JC/6BC	40	91.5	30	79.5	41	20	78
PD40-30B□6JC/6BC		104.5		92.5	54	30	85
PD40-40B□6JC/6BC		117.5		105.5	67	40	91
PD40-50B□6JC/6BC		130.5		118.5	80	50	98
PD50-20B□6JC/6BC	50	93.5	32	81.5	41	20	82
PD50-30B□6JC/6BC		106.5		94.5	54	30	89
PD50-40B□6JC/6BC		119.5		107.5	67	40	95
PD50-50B□6JC/6BC		132.5		120.5	80	50	102

备注: 1.表格内□填入吸盘材质, 多种材质可以选择, 不同应用选用不同材质的吸盘。
2.所有金属支架的接头6J&6B可以互换, 6JC&6BC可以互换。

- 标准型
- 波纹风箱型
- 柔软型
- 柔软波纹风箱型
- 椭圆形
- 薄物用型
- 防滑型
- 长行程型
- M F 型
- M J 型
- M C 型
- M A 型
- G U 型
- G C 型
- G B 型
- 防掉落阀

单位: mm

PC 长行程顶部真空端口
椭圆形—内置弹簧

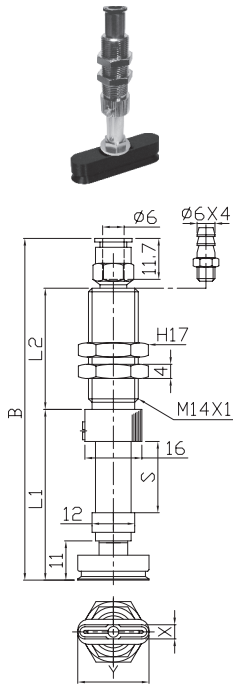

型号	吸盘外径(φd)		B	L1	L2	S 行程	质量 (g)
	X	Y					
PC4 × 10-10E□6J/6B	4	10	69	35	20	10	38
PC4 × 10-15E□6J/6B			79	40	25	15	42
PC4 × 10-20E□6J/6B			95	47	34	20	49
PC4 × 20-10E□6J/6B	4	20	69	35	20	10	38
PC4 × 20-15E□6J/6B			79	40	25	15	43
PC4 × 20-20E□6J/6B			95	47	34	20	50
PC4 × 30-10E□6J/6B	4	30	69	35	20	10	39
PC4 × 30-15E□6J/6B			79	40	25	15	43
PC4 × 30-20E□6J/6B			95	47	34	20	50
PC5 × 10-10E□6J/6B	5	10	69	35	20	10	38
PC5 × 10-15E□6J/6B			79	40	25	15	42
PC5 × 10-20E□6J/6B			95	47	34	20	49
PC5 × 20-10E□6J/6B	5	20	69	35	20	10	38
PC5 × 20-15E□6J/6B			79	40	25	15	43
PC5 × 20-20E□6J/6B			95	47	34	20	50
PC5 × 30-10E□6J/6B	5	30	69	35	20	10	39
PC5 × 30-15E□6J/6B			79	40	25	15	43
PC5 × 30-20E□6J/6B			95	47	34	20	50
PC6 × 10-10E□6J/6B	6	10	69	35	20	10	38
PC6 × 10-15E□6J/6B			79	40	25	15	42
PC6 × 10-20E□6J/6B			95	47	34	20	49
PC6 × 20-10E□6J/6B	6	20	69	35	20	10	38
PC6 × 20-15E□6J/6B			79	40	25	15	43
PC6 × 20-20E□6J/6B			95	47	34	20	50
PC6 × 30-10E□6J/6B	6	30	69	35	20	10	39
PC6 × 30-15E□6J/6B			79	40	25	15	43
PC6 × 30-20E□6J/6B			95	47	34	20	50
PC8 × 20-10E□6J/6B	8	20	69	35	20	10	38
PC8 × 20-15E□6J/6B			79	40	25	15	43
PC8 × 20-20E□6J/6B			95	47	34	20	50
PC8 × 30-10E□6J/6B	8	30	69	35	20	10	39
PC8 × 30-15E□6J/6B			79	40	25	15	43
PC8 × 30-20E□6J/6B			95	47	34	20	50

PC 长行程顶部真空端口
椭圆形—外置弹簧

单位: mm

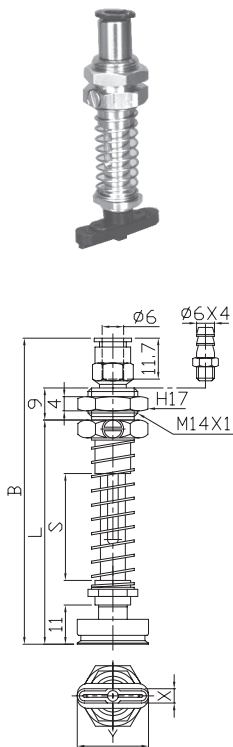

型号	吸盘外径(φd)		B	L	S 行程	质量 (g)
	X	Y				
PC4 × 10-20E□6JC/6BC	4	10	72	49	20	45
PC4 × 10-30E□6JC/6BC			85	62	30	50
PC4 × 10-40E□6JC/6BC			98	75	40	55
PC4 × 10-50E□6JC/6BC			111	88	50	61
PC4 × 20-20E□6JC/6BC	4	20	72	49	20	45
PC4 × 20-30E□6JC/6BC			85	62	30	51
PC4 × 20-40E□6JC/6BC			98	75	40	56
PC4 × 20-50E□6JC/6BC			111	88	50	61
PC4 × 30-20E□6JC/6BC	4	30	72	49	20	46
PC4 × 30-30E□6JC/6BC			85	62	30	51
PC4 × 30-40E□6JC/6BC			98	75	40	56
PC4 × 30-50E□6JC/6BC			111	88	50	62
PC5 × 10-20E□6JC/6BC	5	10	72	49	20	45
PC5 × 10-30E□6JC/6BC			85	62	30	50
PC5 × 10-40E□6JC/6BC			98	75	40	55
PC5 × 10-50E□6JC/6BC			111	88	50	61
PC5 × 20-20E□6JC/6BC	5	20	72	49	20	45
PC5 × 20-30E□6JC/6BC			85	62	30	51
PC5 × 20-40E□6JC/6BC			98	75	40	56
PC5 × 20-50E□6JC/6BC			111	88	50	61
PC5 × 30-20E□6JC/6BC	5	30	72	49	20	46
PC5 × 30-30E□6JC/6BC			85	62	30	51
PC5 × 30-40E□6JC/6BC			98	75	40	56
PC5 × 30-50E□6JC/6BC			111	88	50	62
PC6 × 10-20E□6JC/6BC	6	10	72	49	20	45
PC6 × 10-30E□6JC/6BC			85	62	30	50
PC6 × 10-40E□6JC/6BC			98	75	40	55
PC6 × 10-50E□6JC/6BC			111	88	50	61
PC6 × 20-20E□6JC/6BC	6	20	72	49	20	45
PC6 × 20-30E□6JC/6BC			85	62	30	51
PC6 × 20-40E□6JC/6BC			98	75	40	56
PC6 × 20-50E□6JC/6BC			111	88	50	61
PC6 × 30-20E□6JC/6BC	6	30	72	49	20	46
PC6 × 30-30E□6JC/6BC			85	62	30	51
PC6 × 30-40E□6JC/6BC			98	75	40	56
PC6 × 30-50E□6JC/6BC			111	88	50	62
PC8 × 20-20E□6JC/6BC	8	20	72	49	20	45
PC8 × 20-30E□6JC/6BC			85	62	30	51
PC8 × 20-40E□6JC/6BC			98	75	40	56
PC8 × 20-50E□6JC/6BC			111	88	50	61
PC8 × 30-20E□6JC/6BC	8	30	72	49	20	46
PC8 × 30-30E□6JC/6BC			85	62	30	51
PC8 × 30-40E□6JC/6BC			98	75	40	56
PC8 × 30-50E□6JC/6BC			111	88	50	62

备注: 1.表格内□填入吸盘材质, 多种材质可以选择, 不同应用选用不同材质的吸盘。
2.所有金属支架的接头6J&6B可以互换, 6JC&6BC可以互换。

分类 类型	吸盘型号	吸盘螺丝型号	螺纹体型号	适配器型号	分类 类型	吸盘型号	吸盘螺丝型号	螺纹体型号	适配器型号
标准型吸盘	P10R□	PM46-6	-	-	椭圆形	P□ × 10E□	-	FSPH10	-
	P15R□	PM46-6	-	-		P□ × 20E□	-	FSPH20	-
	P20R□	PM610-8	-	-		P□ × 30E□	-	FSPH20	-
	P25R□	PM610-8	-	-	柔软型吸盘	P4L□	-	-	FVPL15-M4
	P30R□	PM612-10	-	-		P6L□	-	-	FVPL15-M4
	P40R□	PM610-15	-	-		P8L□	-	-	FVPL15-M4
	P50R□	PM610-15	-	-		P10L□	-	-	FVPL15-M4
	P60R□	PM1018	-	-		P15L□	-	-	FVPL15-M4
	P80R□	PM1018	-	-		P20L□	-	-	FVPL40-M6
	P100R□	PM1018	-	-		P30L□	-	-	FVPL40-M6
	P150R□	PM2028	-	-		P40L□	-	-	FVPL40-M6
	P200R□	PM2028	-	-	柔软波纹风箱型	P6LB□	-	-	FVPL15-M4
防滑型吸盘	P10KNH	PM46-6	-	-		P8LB□	-	-	FVPL15-M4
	P20KNH	PM610-8	-	-		P10LB□	-	-	FVPL15-M4
	P30KNH	PM612-10	-	-		P15LB□	-	-	FVPL15-M4
	P40KNH	PM610-15	-	-	P20LB□	-	-	FVPL40-M6	
	P50KNH	PM610-15	-	-	波纹风箱型吸盘	P10B□	PM46-6	-	-
P20B□	PM610-8	-	-	P20B□		PM610-8	-	-	
P30B□	PM612-10	-	-	P30B□		PM612-10	-	-	
P40B□	PM610-15	-	-	P40B□		PM610-15	-	-	
P50B□	PM610-15	-	-	P50B□		PM610-15	-	-	
P80B□	PM1018	-	-	P80B□		PM1018	-	-	

- 标准型
- 风箱型
- 柔软型
- 柔软波纹风箱型
- 椭圆形
- 薄物用型
- 防滑型
- 长行程型
- M F 型
- M J 型
- M C 型
- M A 型
- G U 型
- G C 型
- G B 型
- 防掉落阀